



TAKEDO[®] - 3VF HYDROVERT V20

USER MANUAL

2.1	10-08-2017	R. Bocconi
REV.	DATE	Check and Approval R.T.

INDEX

1 - INTRODUCTION	Page	3
2 - RECOMMENDATIONS AND PRECAUTIONS	Page	3
3 - CONNECTION OF THE POWER CIRCUIT	Page	4
4 - CONTROL CIRCUITS	Page	5
5 - BASIC APPLICATION DRAWING	Page	6
5.1 – OIL TEMPERATURE MEASUREMENT PROBE	Page	7
6 - KEYBOARD AND PROGRAMMING	Page	8
7 - MONITOR MENU	Page	9
8 - PARAMETERS MENU	Page	10
9 - FAULTS MENU	Page	12
10 - ADJUSTMENT PROCEDURE	Page	14
10.1 – UPWARD RUN Adjustments	Page	14
10.2 – UPWARD START Adjustments	Page	15
10.3 – UPWARD STOP Adjustments	Page	15
10.4 – RE-LEVELLING Adjustments	Page	16
10.5 – MAXIMUM INPUT POWER Adjustments	Page	16
11 - CONTROLS AND MAINTENANCE	Page	17
12 - DIMENSIONS AND FIXING	Page	18
VACON DECLARATION OF CONFORMITY	Page	19

1 – INTRODUCTION

HYDROVERT V20 is a new inverter model with built-in EMC filter in compliance with 2004/108/EC (Electromagnetic Compatibility) and 2006/95/EC (Low Voltage) Directives, fitted with special software for hydraulic systems, which can operate with both old and new control units.

Controls only the UPWARD run phase.

The following advantages are attained:

- **No peak currents. The maximum start-up current is the nominal current.**
- **Possibility of setting a network maximum input power limit, to contain the contractual power.**
- **Reduction of consumptions.**
- **Optimisation of run comfort.**
- **Power factor correction of the network input power. Cosφ 0.98.**
- **Possibility of selecting the inspection speed value.**

HYDROVERT V20 is available for motors with maximum input current up to 27A.

A TABLE is given successively, which states the indicative INPUT POWER and ENGAGED POWER values that can be obtained with HYDROVERT V20, highlighting the possible saving with respect to the application of a simple SOFT STARTER.

MOTOR DATA			INPUT POWER (kW)		ENGAGED POWER (kW)	
PLATE POWER (kW)	NOMINAL CURRENT (A)	MAXIMUM CURRENT (A)	With NOMINAL current	With MAXIMUM current	SOFT STARTER	HYDROVERT
2.2	7.1	9	3.9	5	6	4.5
3	8.6	11	4.7	6	6	4.5
4.7	13	16	7.2	8.8	10	6
6	15	21	8.3	11.6	15	6

TABLE 1 – Input Power and Engaged Power

2 – RECOMMENDATIONS AND PRECAUTIONS

For everything that concerns the recommendations relative to **personal safety** and **to prevent accidental damage to the product or equipment** connected to it, refer to the “**SAFETY**” chapter in the original VACON INSTALLATION AND MAINTENANCE TECHNICAL MANUAL (VACON 20 Cold Plate series inverter) available at www.it.vacon.com, where the “Declaration of Conformity”, given on the last page of this document, is also present.

Read this manual completely before powering the appliance.

Regarding specific application on elevators, also carefully consider the following points:

- 1- **The inverter leakage current to earth is over 30mA**, a residual current device must therefore be envisioned with **I_d no less than 300mA; type B or type A**. For the earth connection, the regulations prescribe a cable with minimum section of 10 mm².
If, on closing the master switch, the RCD intervenes, do not repeat the operation several times successively because the inverter could undergo permanent damage.
- 2- **To prevent damage to the inverter in the event of prolonged standstill without power supply, before re-starting it is necessary:**
 - **If the inverter is at a standstill for several months, power it for at least 1 hour in a way to regenerate the bus condensers.**
 - **If the inverter is at a standstill for more than 1 year, power it for 1 hour with voltage that is 50% lower than the nominal voltage and then for 1 hour at nominal voltage.**

3 – CONNECTION OF THE POWER CIRCUIT

L1;L2;L3	Network power supply input	Connect the three power supply network input phases, independently of the cyclic direction.
U;V;W	Inverter outlet	Connect the three output phases to the contactors and therefore to the motor
	Earth	Connect to the system earth

For the dimensioning of the cables and the position of the terminals, refer to the “POWER CONNECTIONS” chapter in the original VACON INSTALLATION AND MAINTENANCE TECHNICAL MANUAL (**VACON 20 Cold Plate** series inverter) available at www.it.vacon.com.

HYDROVERT V20 400 VOLT

RATED CURRENT (A)	MAXIMUM CURRENT (A)	CODE	DIMENSIONS LxHxD (mm)	FUSES gG/gL (A)
18	19.6	HVV00184	175x275x140	20
27	29,7	HVV00274	175x275x140	25

TABLE 2 – Currents and fuses for 400V power supply voltage

4 – CONTROL CIRCUITS

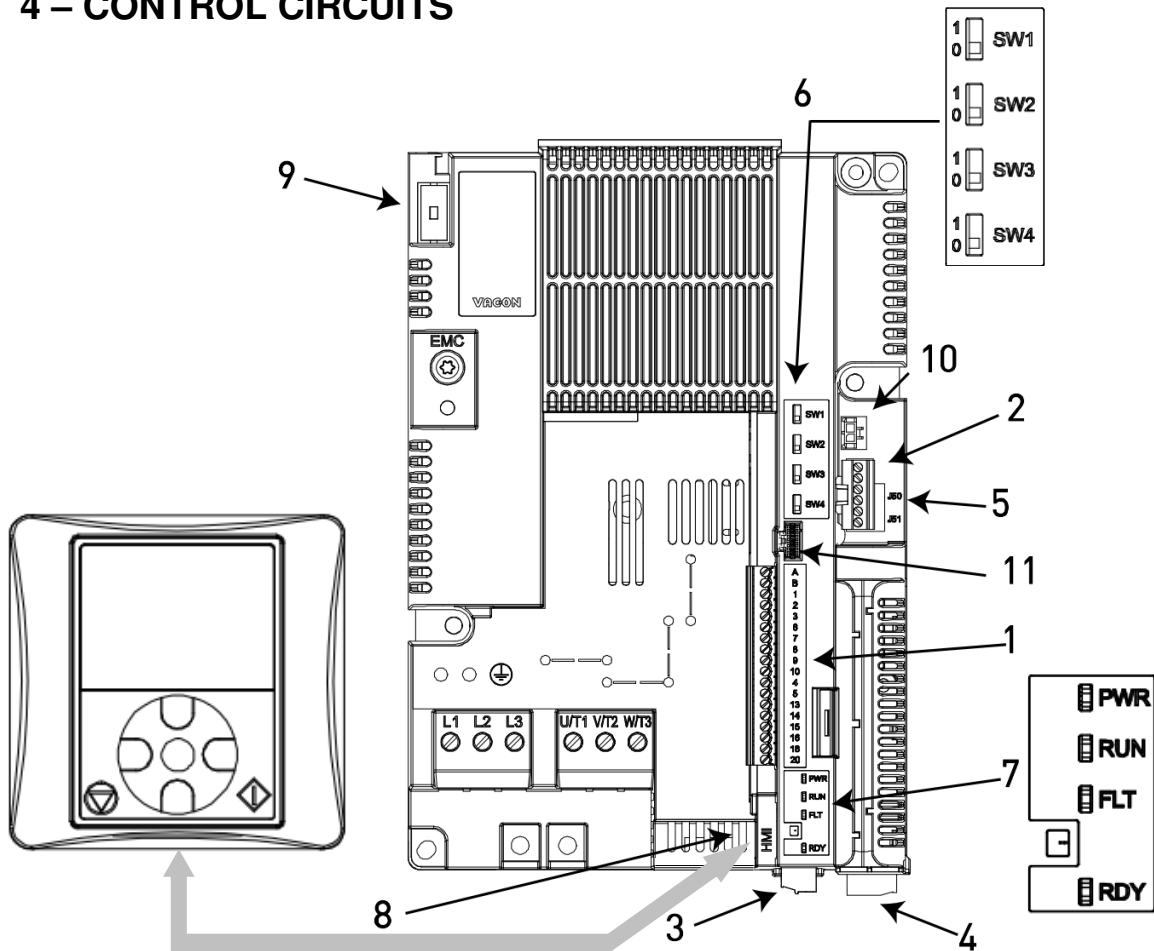

Number	Description
1	Control Terminals A-20
2	Terminals STO
3	Relay Terminals
4	Optional Board Terminals
5	Jumpers STO
6	DIP Switch: SW1 in position 0 , the digital inputs common (8-10 and 14-16) is connected to earth (pre-defined position); in position 1 , the above-mentioned common is isolated from earth. SW2 analogue input operation AI1; SW3 analogue input operation AI2; in position 0 , the analogue input selected works in current; in position 1 , the analogue input works in voltage; the voltage range is 0...10V and current range is 0/4...20mA. SW4 used for the termination of the bus in the RS485 connection; in position 0 , the termination resistance is connected; in position 1 no (pre-defined position).
7	Status LED: "PWR" Orange the inverter is powered by the network "RUN" Green the inverter is in operating mode "FLT" Red the inverter has an anomaly "RDY" Orange the inverter is READY and there are no anomalies it flashes when an alarm is triggered
8	HMI RJ45 connector for control panel (Keyboard/PC)
9	Braking Resistance Terminals (not used for this application)
10	Power supply connector for fan
11	A-20 echo connector

5 – BASIC APPLICATION DRAWING

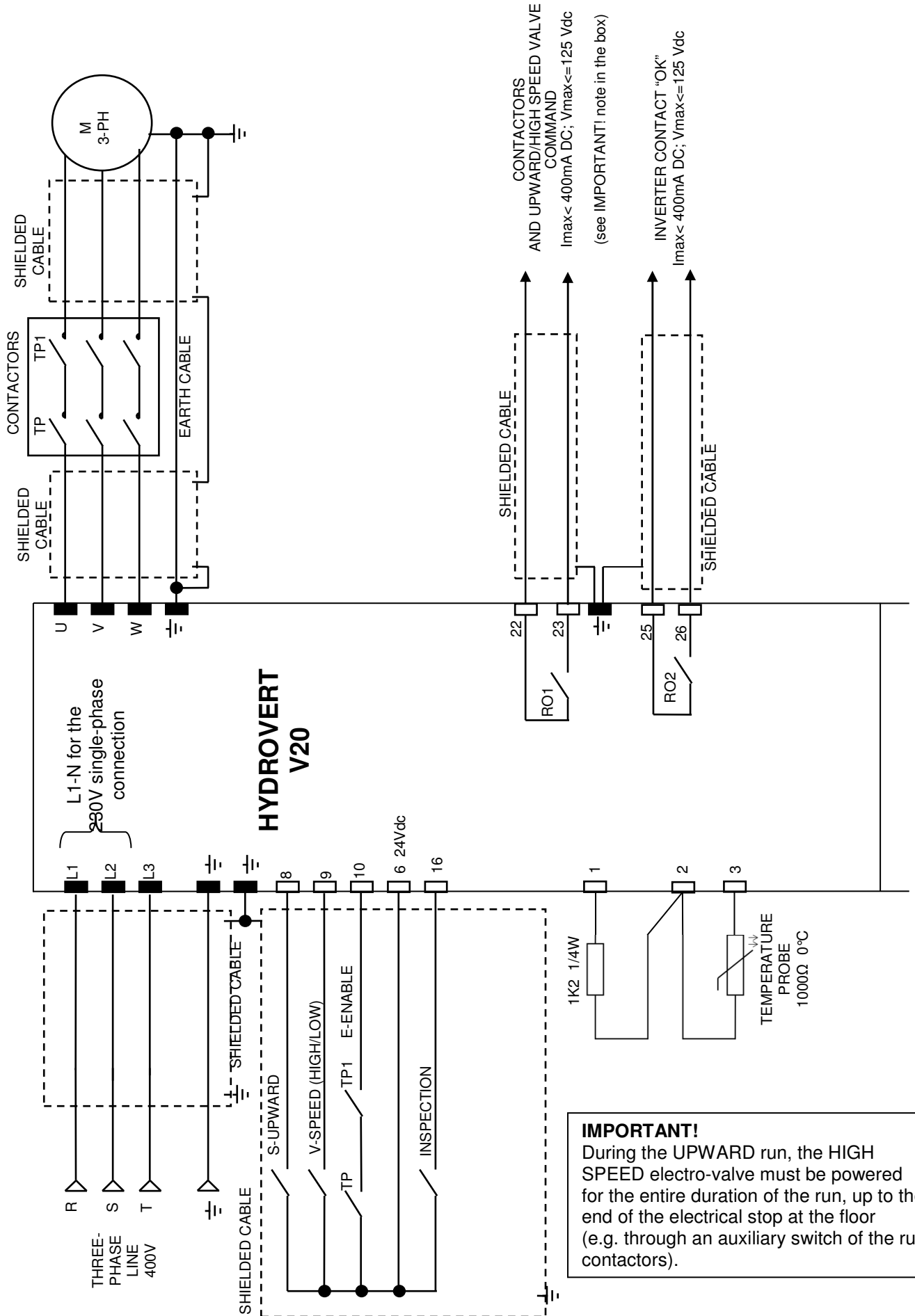

5.1 – OIL TEMPERATURE MEASUREMENT PROBE

ASSEMBLY OF THE PROBE INSIDE THE HYDRAULIC CONTROL UNIT

Immerse the bulb of the control unit oil probe, paying attention that it does not touch the bottom but remains in the oil bath even with the cabin at the extreme top floor.

INVERTER SETTINGS

The ANALOGUE input 1 (terminal 2), must be configured in “VOLTAGE”:



Switch **SW2** in position **1**

Connect the probe as indicated in the layout

To set the relative parameters, see Paragraph 10.3, points 4 ÷ 11.

6 – KEYBOARD AND PROGRAMMING

The programming keyboard is the interface between HYDROVERT V20 and the user and must be connected to the connector shown in the figure, via the cable supplied.

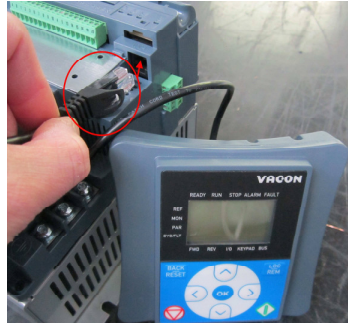

The keyboard can be used to control the state of the motor and the inverter and modify the parameters. The KEYS section is illustrated in the following figure:

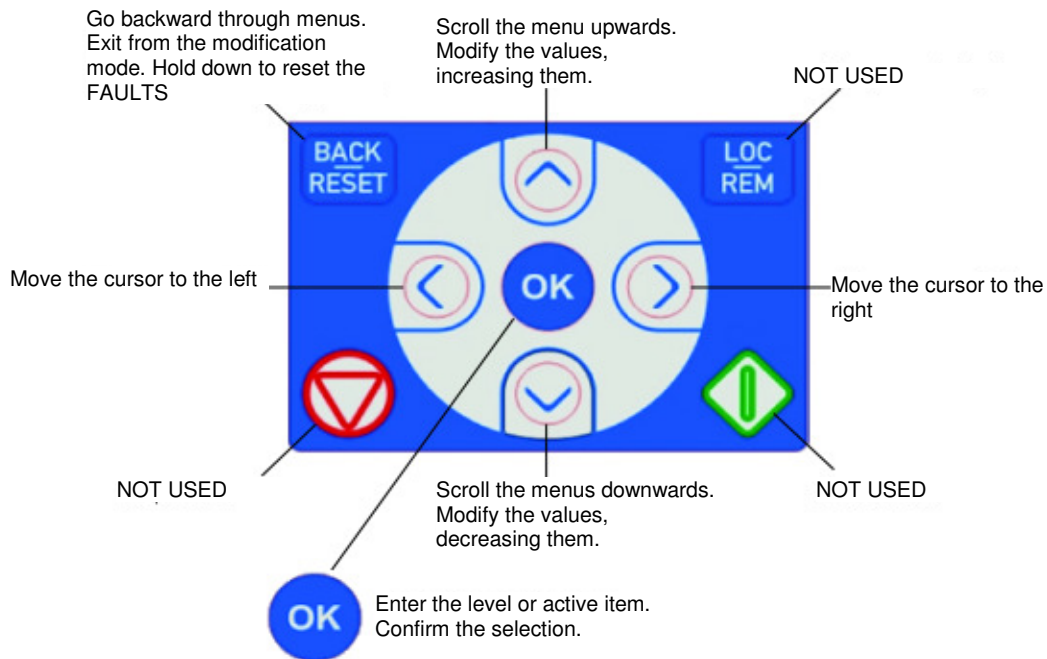

The DISPLAY section indicates the status of the motor and inverter, including any irregularity in operation of the same.

It is possible to see the information regarding the current position inside the menu and the item displayed.

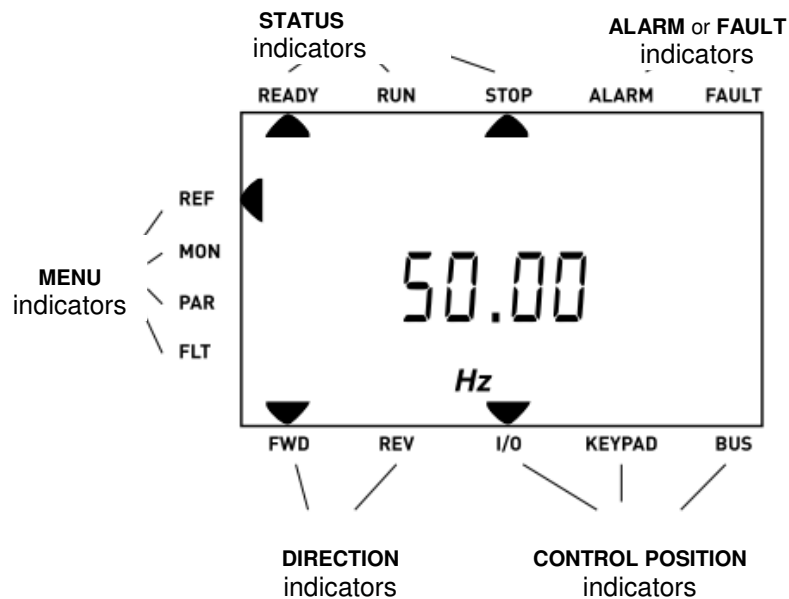

6.1 – MENU STRUCTURE

On the keyboard, the data is divided into Menus.

- Use UP ARROW and DOWN ARROW to scroll the menus.
- Enter the desired group by pressing the OK key and go back to the previous level by pressing the BACK/RESET key.

The arrow on the left of the display indicates the active menu.

The MAIN MENU has the following structure:

Reference from Keyboard	(REF)
Monitor	(MON)
Parameters	(PAR)
Faults	(FLT)
(divided into ACTIVE FAULTS and FAULTS MEMORY)	

6.2 – USING THE KEYBOARD

6.2.1 DATA MODIFICATION

To modify the value of a parameter, follow the procedure below:

1. Identify the parameter
2. Press OK to enter the MODIFICATION mode
3. Set the new value using the UP and DOWN ARROWS.
The value can also be modified number by number, moving from one to another using the RIGHT and LEFT ARROWS.
4. Confirm the modification using the OK key
(or ignore the modification and go back to the previous level by pressing the BACK/RESET key).

6.2.2 RESET FAULTS

When a FAULT appears and the inverter blocks, analyse the causes that led to the intervention of the protection function with the help of the TABLE in Chapter 9.1 – ACTIVE FAULTS, then restore operation by pressing and holding the BACK/RESET key.

7 – MONITOR MENU

This menu allows to display values and data during operation of the inverter and is divided into 2 sub-menus.

Index	Description	Index	Description
1 – Motor			
V1.1	Output frequency	V1.6	Motor power
V1.2	Frequency Reference	V1.7	Motor voltage
V1.3	Motor shaft speed	V1.8	Motor temperature
V1.4	Motor current	V1.9	Final output frequency
V1.5	Motor torque	V1.10	Actual Power
2 – Inverter			
V2.1	DC-link voltage	V2.7	RO1 Contactors (terminals 22-23)
V2.2	Unit temperature	V2.8	RO2 Inverter "OK" (terminals 25-26)
V2.3	Board temperature	V2.9	DO1 Inverter "READY" (terminals 6-20)
V2.4	D11 Upward (terminal 8)	D12 Speed (High/Low) (terminal 9)	D13 Enable (terminal 10)
V2.5	D14 Downward (terminal 14)	D15 Emergency (terminal 15)	D16 Inspection (terminal 16)
V2.6	D17 (terminal 2)	D18 (terminal 4)	STO (terminal STO)
	----- NOT USED -----		
		V2.10	Not Used
		V2.11	Analogue Input 1
		V2.12	Analogue Input 2

8 – PARAMETERS MENU (Default values for 400V series)

Index	Description	Unit	Default	Value
1 – BASIC PARAMETERS				
P1.1	Current limit	A	(**)	
P1.2	Motor nominal voltage	V	400	
P1.3	Motor nominal frequency	Hz	50	
P1.4	Motor nominal speed	rpm	2800	
P1.5	Motor nominal current	A	(*)	
P1.6	Motor φ cos		0.80	
P1.7	Identification		0	
P1.8	Maximum power	kW	15	
2 – CONFIGURATION				
P2.1	Pre-start ramp		0.2	
P2.2	Pre-start frequency	Hz	2.00	
P2.3	Pre-start time	s	0,1	
P2.4	Acceleration time	s	1,5	
P2.5	Deceleration time	s	2,0	
P2.6	High speed	Hz	50	
P2.7	Low speed	Hz	7	
P2.8	Levelling speed	Hz	7	
P2.9	Inspection speed	Hz	25	
P2.10	Final deceleration time	s	0,5	
P2.11	Ramp shape	s	2,00	
P2.12	Losses compensation	rpm	0	
P2.13	No-load current	A	(*)	
P2.14	Max load current	A	(*)	
P2.15	Load compensation	Hz	2	
P2.16	Oil temperature compensation	Hz	0	
P2.17	Power measure %	%	150	
P2.18	Power measure Hz	Hz	20	
P2.19	Current increment with speed	%	30	
P2.20	Decel time correction in power limit	%	120	
P2.21	Minimum load threshold	%	50	
P2.22	Short floor speed	Hz	20	
P2.23	Levelling compensation minimum	Hz	0	
P2.24	Levelling compensation maximum	Hz	1	
P2.25	Levelling minimum current	A	(*)	
P2.26	Levelling maximum current	A	(*)	
3 – DRIVE CONTROL				
P3.1	Brake chopper		0	
P3.2	Brake chopper threshold	V	0	
P3.3	Motor control mode		1	
P3.4	Switching frequency	kHz	8.0	
P3.5	Torque boost		1	
P3.6	U/f ratio selection		2	
P3.7	Field weakening point	Hz	50	
P3.8	Voltage at field weakening point	%	100	
P3.9	U/f curve midpoint frequency	Hz	1.75	
P3.10	U/f curve midpoint voltage	%	5.00	
P3.11	Output voltage at zero frequency	%	3.50	
P3.12	Identification current	%	50	
P3.13	Motor stator voltage drop	%	0.00	
P3.14	Low switching frequency	kHz	5.0	
P3.15	Change switching frequency threshold	Hz	5.00	
P3.16	Low noise modulator		1	
P3.17	Power limit correction	%	100	
P3.18	Current 2nd read delay	s	0,5	
P3.19	Power limit mode		1	
P3.20	Stable current window		0,20	

(*) The value depends on the inverter size and is set on the basis of the type of motor and lift system.

(**) The value depends on the inverter size.

Index	Description	Unit	Default	Value
4 – INPUT SIGNALS				
P4.1	Upward start		1 (DI1)	
P4.2	Downward start		4 (DI4)	
P4.3	High speed		2 (DI2)	
P4.4	Inspection speed		6 (DI6)	
P4.5	Run enable		3 (DI3)	
P4.6	Emergency		5 (DI5)	
P4.7	A3 mode door		0	
P4.8	A3 mode bottom floor		0	
P4.9	Short floor		0	
5 – OUTPUT SIGNALS (see BELOW for CONFIGURATION)				
P5.1	Relay output 1 content		3	
P5.2	Relay output 2 content		1	
P5.3	Digital output 1 content (Open Collector)		1	
P5.4	Analogue Output digital function content		1	
P5.5	Relay output 1 ON delay	s	0.00	
P5.6	Relay output 1 OFF delay	s	0.00	
P5.7	Relay output 1 inversion		0	
P5.8	Relay output 2 ON delay	s	0.00	
P5.9	Relay output 2 OFF delay	s	0.00	
P5.10	Not Used			
P5.11	Not Used			
P5.12	Not Used			
P5.13	Analogue output function		0	
P5.14	Analogue output minimum		0	
P5.15	Analogue output scale	%	100.0	
P5.16	Analogue output filter time	s	0.0	
P5.17	Frequency supervision 1		1	
P5.18	Frequency supervision value 1	Hz	30.00	
6 – PROTECTIONS				
P6.1	Earth fault protection		2	
P6.2	Motor stall protection		0	
P6.3	Motor stall delay	s	5.0	
P6.4	Motor stall minimum frequency	Hz	15.00	
P6.5	Thermal protection of the motor		0	
P6.6	Motor ambient temperature	C	40	
P6.7	Motor cooling factor at zero speed	%	40.0	
P6.8	Motor thermal time constant	M	45	
P6.9	Response to thermistor fault		2	
P6.10	Maximum contactor fault numbers		20	
P6.11	STO Alarm		1	
P6.12	Response to input phase fault		0	
P6.13	Input phases fault max. ripple		0	
P6.14	Enable OFF check		1	
P6.15	Parameters lock		0	

CONFIGURATION OF DIGITAL OUTPUT SIGNALS

The digital outputs (relays, Open Collector) and the analogue output used as digital (P5.1 ÷ P5.4) can assume the following functions:

0 = Fault	4 = Frequency supervision
1 = Ready	5 = Upward start
2 = Valve 1	6 = Valve 2
3 = Motor contactors	7 = No Fault

NOTE: When an output is programmed as frequency supervision (e.g. to control motor speed), the parameters that indicate the output switching values are:

- P5.17** = 0 No supervision
- = 1 Output ON at frequency lower than P5.18 (Default)
- = 2 Output ON at frequency higher than P5.18
- P5.18** = Frequency value at which switching takes place (Default = 30Hz)

Index	Description	Unit	Default	Value
7 – AUTORESET				
P7.1	Automatic restart		1	
P7.2	Trial time	s	60.0	
P7.3	Wait time	s	3.0	
P7.4	Automatic restart trials		3	
8 – EVACUATION				
P8.1	Maximum frequency	Hz	5.00	
P8.2	Switching frequency	kHz	3.0	
9 – TEMPERATURE				
P9.1	Oil temperature measure		1	
P9.2	Initial inverter min. temperature	C	10	
P9.3	Initial inverter max. temperature	C	70	
P9.4	Initial motor max. temperature	%	80	
P9.5	Min. analogue signal	%	46	
P9.6	Max. analogue signal	%	54	
P9.7	Zero analogue signal	%	50	
P9.8	T Min compensation	Hz	0.00	
P9.9	T Max compensation	Hz	0.00	
P9.10	T Zero compensation	Hz	0.00	
10 – AMENDMENT A3				
P10.1	Logic A3 active		0	
P10.2	Check interval	M	240	
P10.3	Closed door time + bottom floor time	M	1	
P10.4	Valves activation time	s	5	
P10.5	Check time out	M	480	
P10.6	EV1 ON delay	s	0.15	
P10.7	EV2 OFF delay	s	0.15	

9 – FAULTS MENU

ACTIVE FAULTS and the FAULTS MEMORY are found in this MENU.

9.1 ACTIVE FAULTS

When a fault occurs, the display shows the relative code flashing.

The most common fault messages are listed below. Do not restore the alarm or the fault before having analysed the causes that have led to the intervention of the protection function.

Always remove the run command before resetting the fault.

Press and hold the BACK/RESET key to restore operation.

9.2 FAULTS MEMORY

The last 10 faults occurring are stored in the FAULTS MEMORY.

Select the FLT Menu, moving the indicator on the left, an S will appear.

Press OK and then the LEFT arrow until F6.1 is displayed: this is the first fault in the memory, i.e. the last that occurred in time. Press OK to display the KEY.

Press BACK/RESET to go back to F6.1 and then DOWN ARROW to pass to the successive fault F6.2, and so on to scroll all faults memorised.

Fault Code	Description
1	Overcurrent: The inverter has detected a current that is too high.
2	Overvoltage: The DC intermediate circuit voltage has exceeded the limits envisioned.
3	Earth fault: The measurement of the current has detected that the sum of the motor phases currents is different to 0, therefore there is a possible current to earth.
5	Load contact: The load contact is open when the START command is active.
8	System fault: Component fault. Faulty operation. No braking resistance connection.
9	Undervoltage: The DC intermediate circuit voltage is below the envisioned voltage limits.
11	Output phases: No current on one or more output phases. The test is performed 3 times, on the 4th it goes into FAULT mode
13	Inverter undertemperature: The temperature of the heat dissipater is below -10°C .
14	Inverter overtemperature: The temperature of the heat dissipater is above 90°C .
15	Motor stall: The motor stall protection has triggered.
16	Motor overtemperature: The inverter motor temperature model has detected overheating of the motor. The motor is presumably overheated.
17	Motor underload: The motor underload protection has triggered.
22	"checksum" error: Parameters recovery from EEPROM failed. □□Component fault.
24	Meter fault: The value displayed by the meters is incorrect.
25	"Watchdog" fault: Microprocessor fault.
34	Internal bus communication
39	Device removal: The optional board or the power unit has been removed.
40	Device unknown: Optional board or power unit unknown.
41	IGBT temperature: The IGBT overtemperature protection device has detected a short term overload current that is too high (motor loaded that does not start).
44	Device modification: The optional board has been changed.
45	Device addition: The optional board has been added.
50	The corresponding current of the analogue input is $< 4\text{mA}$.
52	Panel communication fault: The connection between the command panel and the inverter is interrupted.
53	Field bus fault: The data connection between the field bus Master and the board is interrupted
60	Advanced stop with respect to low speed: The cabin reaches the floor when it is still decelerating
61	Current low.
62	Enable lost during run.
63	Output phases: No current on one or more output phases.
64	Reference low
65	Time out enable: The enable command did not fall after 3" from the fall of the contactors command.
67	Overspeed: Due to an anomaly, the inverter exceeds the maximum frequency.
*68	Advanced contactors opening: (See Alarm 68 NOTE) The contactors between inverter and motor opened before inverter switch off.
69	No Enable: Indicates that the contactors closed signal is not activated (input 10) within 2 sec. from the contactors command (terminals 22-23 output).
71	Identification not occurred: The procedure was not successful. Check the connection between inverter and motor.

NOTE
Alarm 68

After 20 interventions of this alarm, the lift system goes out of service and the RESET key must be pressed to restore operation.

Eliminate the problem by verifying what causes the advanced opening of the contactors.
If the problem remains, contact SMS assistance.

CONTINUOUS INTERVENTION OF ALARM 68, CAN CAUSE THE INVERTER TO BREAK.

10 – ADJUSTMENT PROCEDURE

Before making any adjustment or modification to the parameters, proceed as follows:

- 1 – Enter the motor plate data into parameters P1.1/2/3/4/5/6.
 - 2 – Make an upward command and check that the motor turns in the correct direction.
 - 3 – **PERFORM THE AUTO-TUNING ROUTINE VIA PARAMETER P1.7 – IDENTIFICATION:**
 - Set parameter **P1.7** to 1, and give an upward command within 10 seconds.
 - When the motor contactors energize and the inverter receives commands, on the keyboard the arrow RUN lights on, but the motor stays stopped. After a few seconds the arrow RUN switches off and the arrow STOP lights on (Identification End).
 - If on the keyboard appears “FT 65” it’s not a problem, open and close again the automatic valve on the control panel and go to the next step.
 - Verify that the Identification has been properly made, checking that the value of parameters P3.9-10-11 is **different** from the default one.
- If any value regarding the characteristics of the motor is modified, IDENTIFICATION must be repeated**
- 4 – Set the value desired for the nominal speed P2.6.
 - 5 – Set the value desired for the low speed P2.7.
 - 6 – Set the value desired for the inspection speed P2.9.
 - 7 – Set the upward motor current values with empty cabin in HIGH and LOW speed, proceeding as follows:
 - display the motor current in the MONITOR MENU (V1.4)
 - with empty cabin, give an upward command, read the current value in HIGH SPEED and record it in P2.13
 - then read the current value in LOW SPEED and record it in P2.25.

10.1 – UPWARD RUN Adjustments

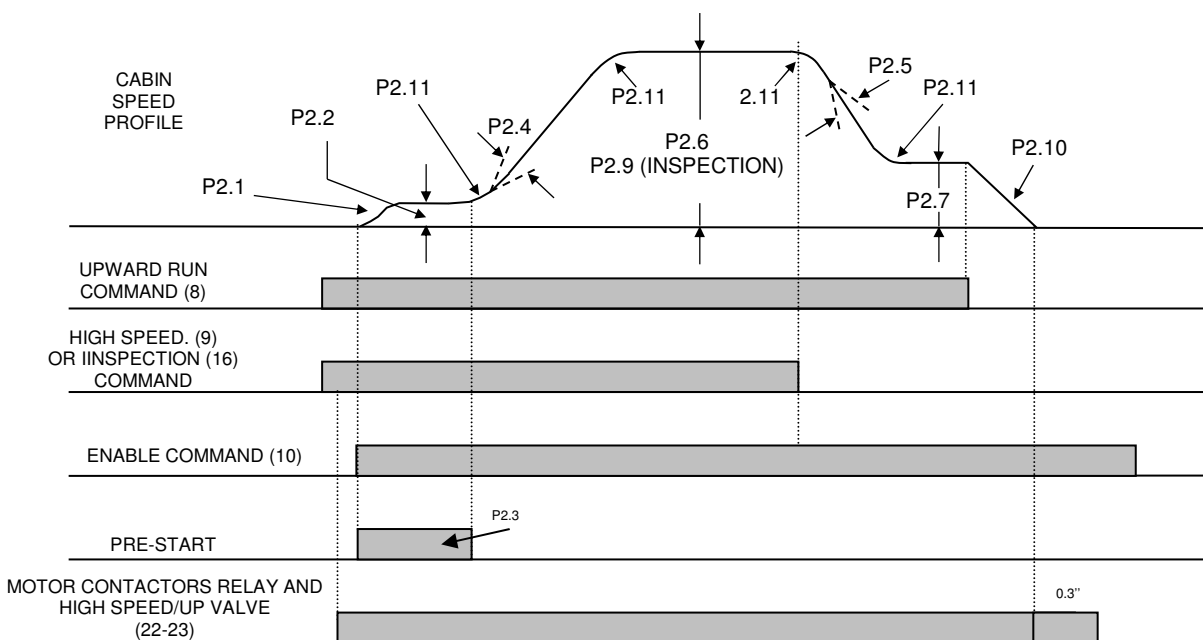

Exact commands sequence

- 1- Entering the UPWARD command (8), the R01 output is excited (22-23). When the contactors are closed, the ENABLE input command must arrive (10): in this way, motor start-up is enabled. If the HIGH or INSPECTION speed level is enabled, the motor will go to “high” or “inspection” speed (P2.6 or P2.9).
- 2- During the normal run, on reaching the slowing command, the HIGH SPEED signal must be removed (9): in this way, the inverter automatically goes to “low” speed (P2.7).
- 3- On reaching the floor, the UPWARD command must be opened (8), the inverter will slow down the motor until it stops, making the R01 contactors command drop (22-23). Consequently the ENABLE command is removed (10).

10.2 – UPWARD START Adjustments

In order to have a good start governed by the inverter, it is good practice to intervene on the hydraulic valve by adjusting the maximum opening, as if to have immediate and rapid start-up without inverter ("open the valve completely").

In order to have "smooth" starts without jerks, the cabin must move slightly before accelerating. This is obtained with parameters P2.1, P2.2, P2.3 adjusted appropriately. Successively, adjust the acceleration with parameters P2.4 and P2.11.

PARAMETER	THE CABIN STARTS WITH A JERK	THE CABIN DELAYS START-UP	THE CABIN ACCELERATES TOO QUICKLY
P2.2	↑	↑	=
P2.3	↑	↑	=
P2.4	=	=	↑
P2.11	↑	=	↑

Key: ↑ to increase the value of the parameter
 ↓ to decrease the value of the parameter
 = the parameter is irrelevant

10.3 – UPWARD STOP Adjustments

When the HIGH SPEED command is removed and the UPWARD command remains, the slowing phase starts; on arrival at the floor the UPWARD command is removed and the motor automatically goes to zero speed.

Adjusting the stop with empty cabin, by setting the parameters P2.7 (Low Speed) and P2.10 (Final Deceleration) in a way to obtain the desired stop accuracy.

PARAMETER	THE CABIN ARRIVES AT THE FLOOR TOO SLOWLY	THE CABIN ARRIVES WITHOUT SLOW SPEED	THE CABIN MOVES AT SLOW SPEED BUT PASSES BEYOND THE FLOOR	AFTER HAVING MOVED AT SLOW SPEED, THE CABIN STOPS BEFORE THE FLOOR
P2.5	↑	↓		=
P2.7	=	=	↓	↑
P2.10	=	=	↓	↑

Display the motor current (V1.4) in the MONITOR menu and check that the value read is set in P2.13.

Stop accuracy can depend on the load in the cabin (weight to be lifted) and the temperature of the oil.

To make stopping accurate in any load condition, proceed as follows:

1. Load the cabin to nominal load, give the command for an upward run and read in the MONITOR menu (V1.4) the motor current in high speed and enter the value in P2.14.
2. Perform the arrival test at the floor with cabin at full load: normally the cabin stops slightly before the floor.
Increase parameter P2.15 until the desired accuracy is obtained.
3. Finally, with the cab empty, control that stopping accuracy has remained that obtained with the initial tests.

To make stopping accurate in any oil temperature condition, proceed as follows:

4. The PT1000 temperature probe must be installed as indicated in Par. 5.1 and connected as in the layout in Par. 5 (terminals 1 - 2 - 3).
5. Check that P2.16 = 0 and enable the inverter on reading the temperature, setting P9.1 = 1.
6. If not already present as factory settings, the reference values of the probe analogue signal must be entered into P9.5 and P9.6:
P9.5 = 46%
P9.6 = 54%.
7. Read the oil temperature value (in %) in the MONITOR menu in V2.11 and enter the value read in P9.7.
8. Make many runs in a way to heat the oil up as much as possible (the oil heats up much quickly if the cabin is loaded).
9. If stopping is not accurate with hot oil (normally the upward cabin stops before the floor, as the heat varies the viscosity of the oil and consequently lowers the levelling speed), increase P9.9 to obtain the same stopping level had with cold oil.

10. Unload the cabin, leave the oil to cool until it reaches its initial temperature and check that the stopping accuracy has not altered.
11. For example, at the first runs in the winter season, if with cold oil the cabin stops higher with respect to the level of the floor, enter the value necessary to obtain accurate stopping into P9.8.

10.4 – UPWARD RE-LEVELLING Adjustments

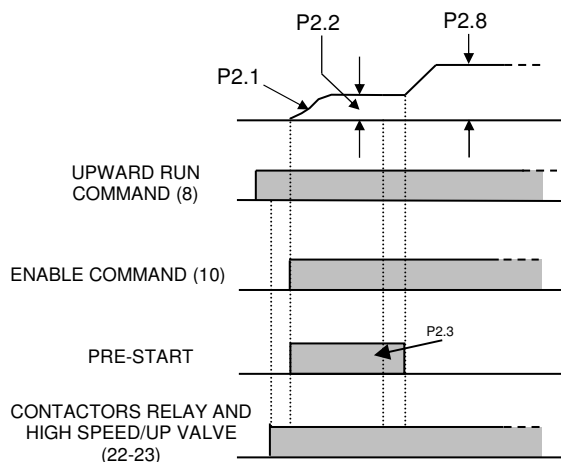

The upward re-levelling run is commanded via the UPWARD inputs (8) and ENABLE (10), IN ABSENCE of any speed command (HIGH SPEED (9) or INSPECTION (16)).

1. With cabin EMPTY, set the parameter P2.8 (re-levelling speed) to the value necessary to obtain the desired stop.
2. Load the cabin to nominal load, give the command for an upward run, read in the MONITOR menu (V1.4) the motor current in LOW SPEED and enter the value in P2.26.
3. Increase parameter P2.24 until there is stopping accuracy at the floor equal to that with empty cabin.

10.5 – MAXIMUM INPUT POWER Adjustments

It is possible to limit the absorbed power, in order to reduce the engaged power and consequently the cost of the energy contract.

The power limitation occurs reducing the cabin speed according to the load.

- Set in P1.8 the maximum power in kW that you want to absorb from the mains.

We suggest you to set P1.8 to a value **not LOWER than the rated power of the pump unit reduced of 25%**, in order to avoid that the speed reduction is active even with empty cabin.

EXAMPLE:

Dataplate Motor Power (kW)	Minimum Power Set in P1.8
7,7	5,8

- Verify the P3.19 “Power Limit Mode” setting.
 - P3.19 = 1 Factory Default – Recommended mode for existing pump unit (modernizations).
 - = 0 Recommended mode for new pump unit, arranged for working with the inverter.
- With load in the cabin (more than 50%), read in the MONITOR menu (V1.10) the absorbed power. If the value is higher than the expected one, decrease P3.17.
- Power limitation takes place by reducing cabin speed, however arrival at the floor and the space travelled at low speed must be the same as those with the cabin empty (when power limitation is not active). If the space travelled in low speed is greater, increase P2.20; if the space travelled in low speed is lower, decrease P2.20 until the desired condition is obtained.

10.6 – General suggestions for correct adjustment

- If cabin speed is not constant in high speed mode, check motor data. In particular, the motor data must correspond with the "real" data. Also check that the mechanical part (cabin/piston) has uniform friction along the run.
- To have a stop with constant precision, the cabin must run a small space (5÷10cm) in low stable speed.
- Adjust the low speed to the desired value, remembering that a very low value increases the arrival time at the floor.
- Do not adjust the switching frequency to values that are too high, otherwise the motor and inverter overheat in vain.

10.7 – Alarms that can appear in the system commissioning phase

- 60 = Advance Stop:
the system arrives at the floor when the low speed has not yet been reached, i.e. it is still in the deceleration phase; in this case, decrease the deceleration time P2.5.
- 63 = Output Phases
:the inverter has detected the lack of current on one or more output phases.
- 68 = Contactors Advanced Opening:
the contactors between inverter and motor have opened BEFORE inverter switch off.
The repeated intervention of this alarm causes the inverter to break and premature wear of the contactors.

11 – CONTROLS AND MAINTENANCE

Cyclically perform the controls given below to guarantee long duration and excellent operation of the inverter. Only intervene on the inverter after having removed the power supply and after having ascertained that the keyboard is off.

- 1- Remove the dust that has accumulated on the cooling fins, possibly using a jet of compressed air or a suction device.
- 2- Check that there are no loose screws in the power or command terminal board.
- 3- Check that inverter operation is <<normal>> and that there are no traces of abnormal overheating.

11.1 MEGGER TEST

When the isolation tests are carried out with a megger on input/output cables or on the motor, remove the connections to all inverter terminals and perform the test only on the power circuit, following the layout in the drawing at the side. Do not perform the test on the command circuits.

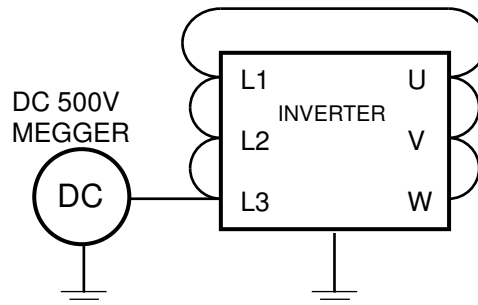

12 – DIMENSIONS AND FIXING

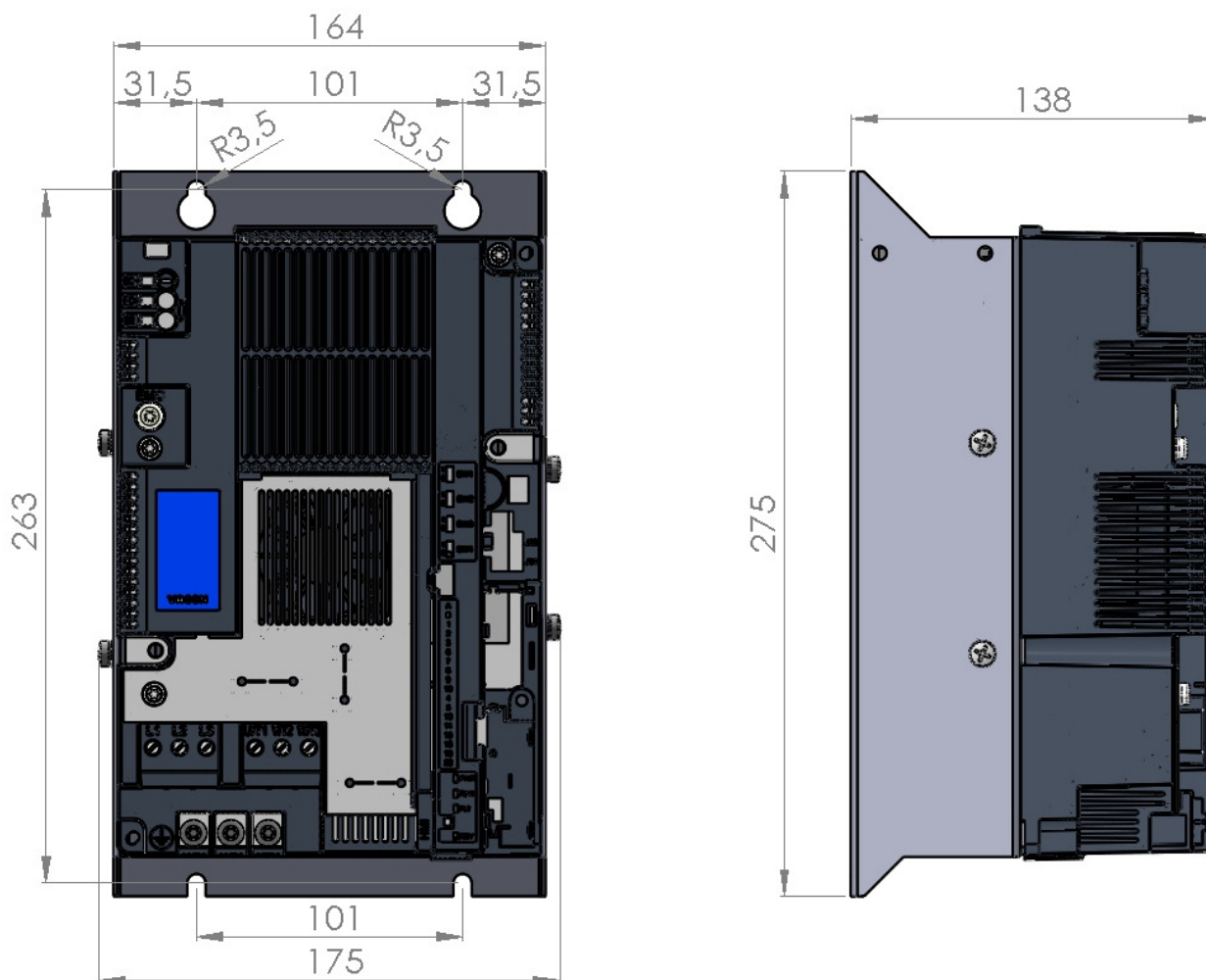

For further information and advice contact:



SMS S.R.L. (Gruppo SASSI HOLDING)

 **E-mail:** sms@sms.bo.it •  **Website:** www.sms-lift.com •  **Tel:** +39 051 969037 •  **Address:** Via Guido Rossa 46-48-50 Loc. Crespellano 40053 Valsamoggia - Bologna - Italy

 **E-mail Technical Assistance:** assistentzatecnica@sms.bo.it •  **Tel. Technical Assistance:** +39 051 6720710

**Danfoss A/S**DK-6430 Nordborg
Denmark
CVR nr.: 20 16 57 15Telephone: +45 7488 2222
Fax: +45 7449 0949**EU DECLARATION OF CONFORMITY****Danfoss A/S****Vacon Ltd**

declares under our sole responsibility that the

Product(s)	Vacon 20 CP and Vacon 20 X AC drives	
Type(s)	Vacon 0020 1L 0004 2...0007 2 CP	Vacon 0020 1L 0004 2...0007 2 X
	Vacon 0020 3L 0004 2...0017 2 CP	Vacon 0020 3L 0004 2...0017 2 X
	Vacon 0020 3L 0003 4...0016 4 CP	Vacon 0020 3L 0003 4...0016 4 X
	Vacon 0020 3L 0003 5...0016 5 CP	Vacon 0020 3L 0003 5...0016 5 X

Product Safety Functions:

Safe Torque Off (EN 61800-5-2:2007) and Emergency stop (EN-60204-1:2006+A1:2009+AC:2010 in extracts) available only on three-phase models.

Covered by this declaration is in conformity with the following directive(s), standard(s) or other normative document(s), provided that the product is used in accordance with our instructions.

EN 61800-5-2:2007
EN 61800-5-1:2007 (LV Directive compliance)
EN 61800-3:2004+A1:2012 (EMC Directive compliance)
EN ISO 13849-1:2008+AC:2009
EN 62061:2005+AC:2010

and conforms to the relevant safety provisions of Low Voltage Directive 2006/95/EC (until April 19th, 2016), 2014/35/EU (from April 20th, 2016) and EMC Directive 2004/108/EC (until April 19th, 2016), 2014/30/EU (from April 20th, 2016), and EC Machinery Directive 2006/42/EC.

Notified body that carried out the EC type examination:TÜV Rheinland Industrie Service GmbH,
Alboinstr. 56, 12103 Berlin / Germany
Certification Body for Machinery NB 0035, Certificate No. 01/205/5215/12 (applied to 480V, 500V)

The year the CE marking was affixed: 2012

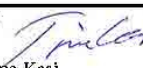
Date 15-04-2016	Issued by Signature  Name: Antti Vuola Title: Head of Standard Drives	Date 15-04-2016	Approved by Signature  Name: Timo Kasi Title: VP, Design Center Finland and Italy
---------------------------	--	---------------------------	--

Danfoss only vouches for the correctness of the English version of this declaration. In the event of the declaration being translated into any other language, the translator concerned shall be liable for the correctness of the translation

ID No: DPD01851 Revision No: A

Page 1 of 1