



# PWM0804, 3 PHASES BATTERY POWERED INVERTER

## USER MANUAL

<b>01</b>	29-08-2018	<i>Poco - Riccardi</i>
REV.	DATE	Check and approval R.T.
SOFTWARE		SCHEDA PWM804 : R00

### 1 – DESCRIPTION

The device is used in rope lift systems, in order to supply the main motor during the rescue operation.

When it is supplied by a battery voltage of appropriate value, it provides the motor a 3-phase supply with adjustable voltage and frequency.

Device	Product Code	Motor Power 380/415Vac (both VVVF and 1 or 2 speed)	Recommended Batteries
PWM 080	202.06.PWM0804	~17,0kW ÷ 40kW 36A ÷ 80A nominali	N.4 da 12V 7Ah N.4 da 12V 12Ah

When the device is activated (RUN command goes ON), it makes the motor move in both the run directions, testing the absorbed current; if in the second test the current is lower, the motor continues to move in that direction, otherwise it stops then moves in the first tested direction (if the current flows from the motor to the batteries (regenerated current), the run direction can be chosen even at the first trial).

If the overcurrent protection trips during the first test, the device stops, reverses the run direction, then starts again its operation; if the overcurrent protection trips even in the second test, the protection trip is memorized and to reset it you must cut off the power supply or the run command from the device.

The overcurrent level adjustment is set during the device test in the factory, and it mustn't be modified.

If you want to force the run in a definite direction, instead of choosing it depending on the lower current absorption, you must supply PWM with batteries 72V or 96V, in order to allow the motor to have the nominal torque. In this case it's necessary to activate also the UP or DOWN command, together with the RUN command.

The output short-circuit protection is only ensured if a 3-phase choke (not supplied) is connected between the inverter PWM output and the motor.

The device carries out the brake coil supply, through a rectifier and a control relay, activated by the inverter run.

There is a minimum current control, to avoid the motor is pulled by the load: if the current absorbed by the motor goes down under the value set by trimmer I (P2), the emergency run is carried on with "jogging" operation (the brake opens and closes with a set frequency).

This type of operation is done for safety reason, in order to avoid both the reaching of a dangerous speed, and the possible damage to the PWM inverter (due to the excessive increase of the voltage on the output, due to the motor regeneration).

### 2 – TECHNICAL CHARACTERISTICS

- Battery Voltage (Vbat): 48 – 72 – 96Vdc
- 3-phase Output Voltage: from 0.32Vbat to 0.75 Vbat  
(Esemple: from 15 to 36 Vac with 48V batteries)
- Output Frequency: 1 ÷ 10 Hz.
- Maximum Peak Output Current: 115A

#### Software protections:

- Current limit (peak) absorbed from batteries: 115A
- Battery check: discharged at -25%, overcharged at +25%, referred to the nominal voltage
- Minimum motor current detector
- Detector of the current regenerated towards batteries
- Voltage check on the brake circuit

**Hardware protections:**

- PTC for short-circuit protection on the OUP and ODN run direction signals.

**Accessori:**

- 3-Phase Choke 60A for PWM output protection

**3 – COLLEGAMENTI**

The PWM device must be supplied with the necessary battery voltage at terminals PA – NA (M2 terminal board) for the power part, and with 48Vdc (referred to NA) at the terminal +48VIN on the M2 terminal board, for the operation logic.

The device switch on, is controlled through the commands on the M2 terminals on the board:

- +CM Comune comandi
- RUN Comando marcia
- UP Comando marcia salita
- DN Comando marcia discesa

The RUN command makes the device to start its operation; if you need to force the run in a definite direction, it's necessary to activate also the UP or DOWN command, together with the RUN command.

The output voltage for the motor is located on the UA, VA, WA terminals.

The brake control is located on the M1 terminal board (B~, B~ input voltage; B+, B- output).

There are three open collector outputs (24V 250 mA) at terminals OUP-ODN-ORS on the M2 terminal board:

- OUP Up run direction signal (OUP +CM)
- ODN Down run direction signal (ODN - +CM)
- ORS Extra, not currently used

For a complete summary of the functions, adjustments a signals of the PWM inverter, see paragraph 4.

**EXAMPLE OF DRAWING FOR RESCUE OPERATION WITH PWM INVERTER - 48V**

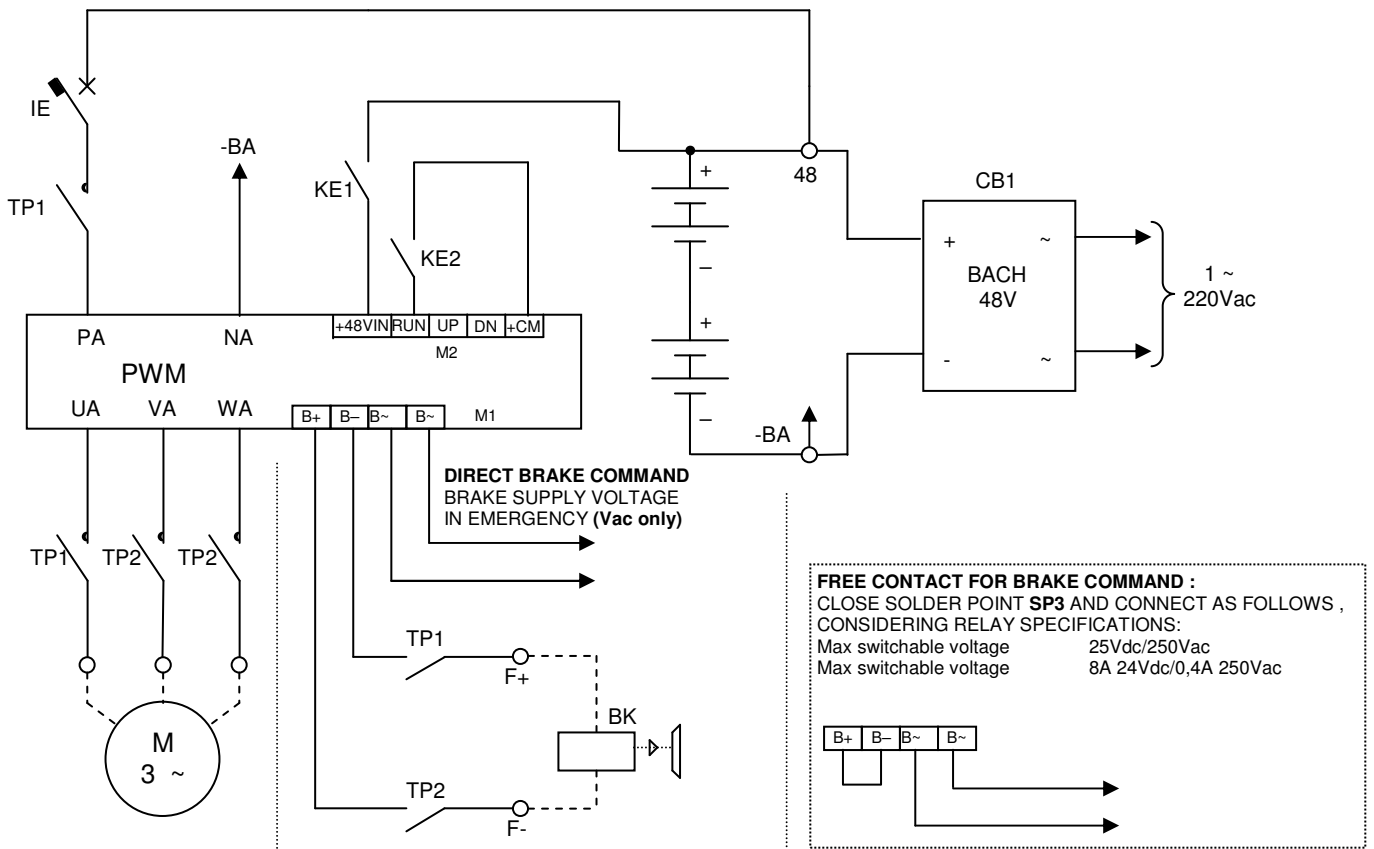

- |     |                     |         |  |
|-----|---------------------|---------|--|
| M   | motor               | TP1,TP2 | motor contactors in rescue operation   |
| BK  | brake               | KE1     | rescue operation start command   |
| CB1 | battery charger 48V | KE2     | PWM inverter switch-on command   |
| IE  | main switch         |         | (it must be activated at least 100msec after the TP1-TP2 energization and it must be cut off at least 100 msec before the TP1-TP2 de-energization) |

## 4 – FUNCTION, ADJUSTMENT AND SIGNAL SUMMARY

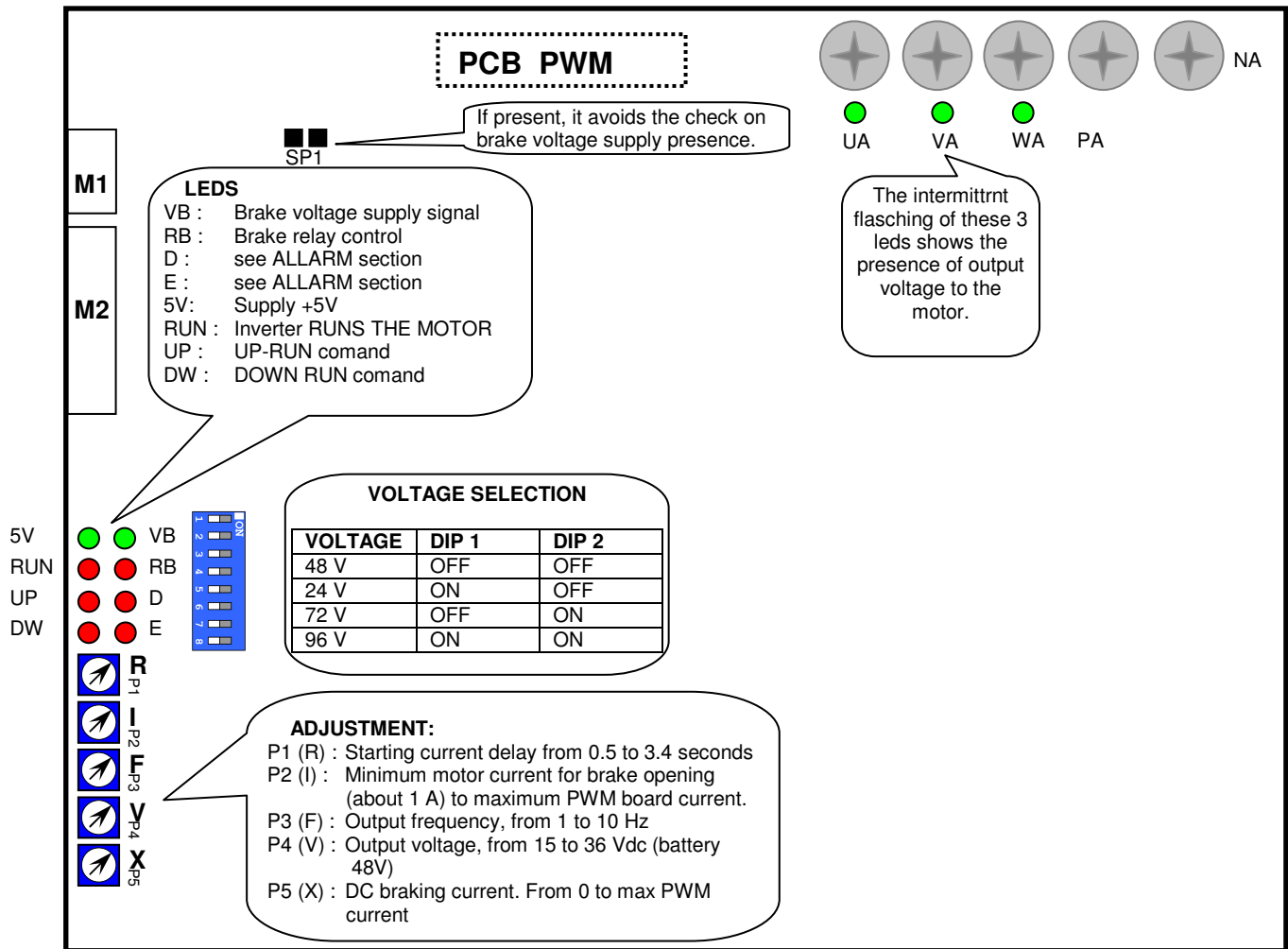

BOARD TERMINALS	
<p>: Motor inverter outputs UA, VA, WA</p> <p>: Power supply inputs PA (+), NA (-)</p> <p><b>M1</b> : Brake – Supply (B~, B~) and comand (B+, B-)</p>	<p><b>M2:</b></p> <p>+48VIN PWM logic part supply</p> <p>RUN Run input – 24V</p> <p>UP Forced UP Run – 24V</p> <p>DN Forced DOWN Run – 24V</p> <p>+CM PWM command common</p> <p>OUP Open Collector output “up run signal”</p> <p>ODN Open Collector output “down run signal”</p> <p>ORS Not used</p>

**OTHER DIPSWITCHES**

DIP3 : SVM MODULATION OFF = DISABLED, ON = ENABLED  
 To be used for asynchronous motors to increase output voltage, and therefore motor torque by adding the third harmonics to the output.

DIP4 ÷ DIP8 : Not used, leave in OFF position.

ALLARMS		Description	Note
Led DL D	Led DL E		
●	○	Batterie voltage too low	<p>Callout :</p> <p>○ = Led off</p> <p>● = Led on</p> <p>* = Led flashing</p>
○	●	Batterie voltage too high	
●	●	Brake voltage missing	
*	○	Output current too low	
○	*	Output peak current too high	
*	*	Output average current too high	

## 5 – DIMENSIONS AND FIXINGS

Width (mm)	Height (mm)	Depth (mm)	Weight (kg)
160	180	80	1,0

X = 0  
Y = 0

X tot = 160

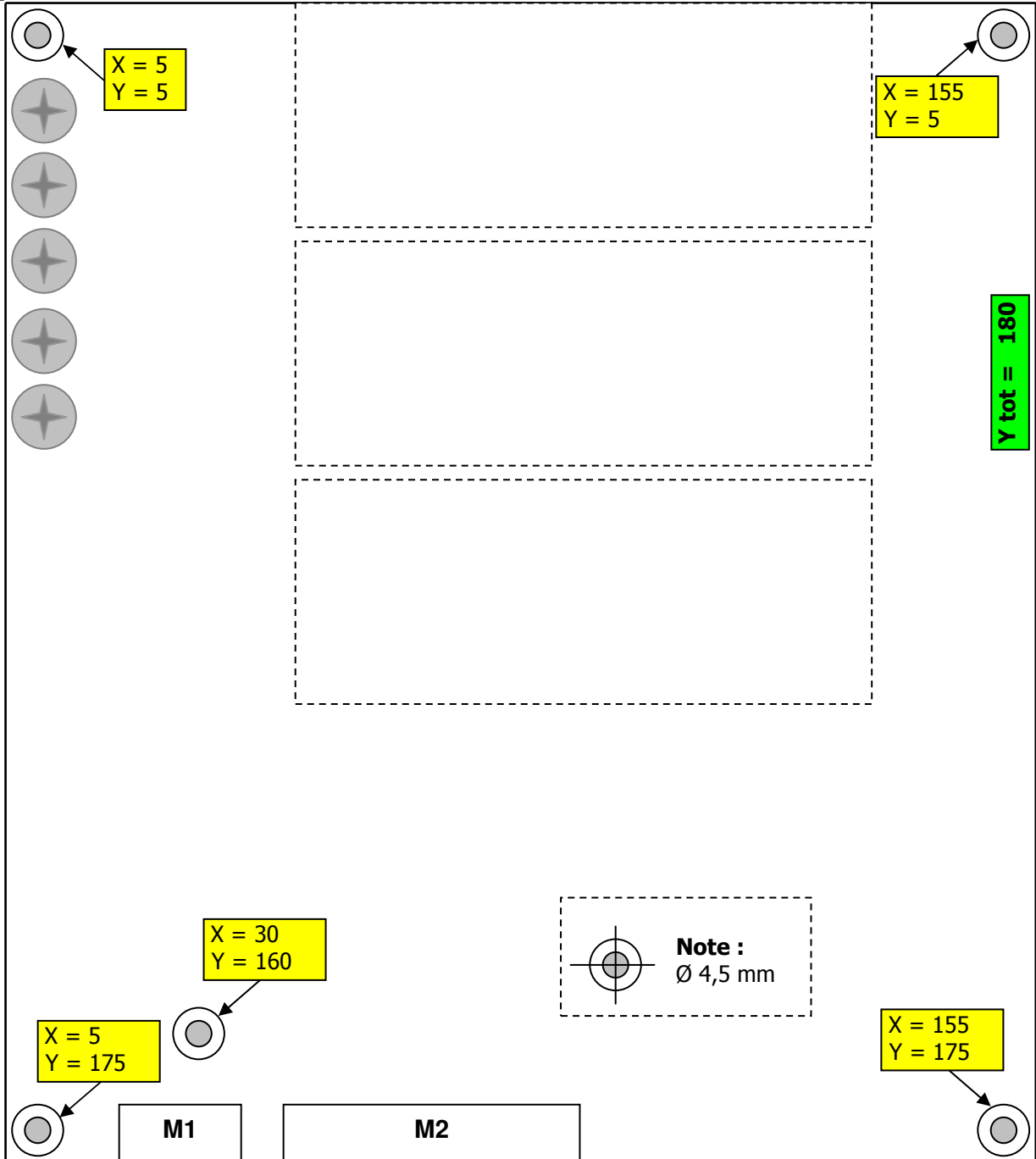

For further information or request, please contact:

**SMS SISTEMI e MICROSISTEMI s.r.l. (Gruppo SASSI HOLDING)**

Via Guido Rossa, 46/48/50 Loc. Crespellano 40053 Valsamoggia BO - ITALIA

Tel. : +39 051 969037 Fax : +39 051 969303 Tel. Tecnical support : +39 051 6720710

E-mail : sms@sms.bo.it Internet : [www.sms-lift.com](http://www.sms-lift.com)