











PWB 3-PHASE INVERTER FOR RESCUE OPERATION

INSTRUCTION MANUAL

4.1	15-07-2014	
REL.	DATE	T.M. Check and Approval

1 – SAFETY

SMS would like to thank you for choosing **PWB**, the 3-phase inverter for rope lifts rescue operation and recommends to read carefully the following indications for your safety.

Point	Memo	Description
1		The metallic case of the device has sharp edges. Handle it with care using suitable gloves for the purpose.
2		The device has a considerable weight. Be careful once it has been lifted from the ground in supporting or fixing to a wall.
3		If the device is clearly damaged, missing parts, or the size of the device is not correct for the lift, absolutely do NOT proceed with the installation.
4		The installation, control and maintenance of the device must be carried out only by qualified personnel and only when the power supply is disconnected. Improper installation can cause equipment malfunction, injury, or even death. Carefully follow the safety directives.
5		Before making any connections, make sure that the supply sources are switched off. Avoid any kind of external object enters the device as it can lead to the failure of the or hazardous conditions at the time of connection to the mains.
6		Connect the ground of the device to the installation ground for the protection against indirect contact, according to the safety directives. Properly protect all connections to prevent accidental contact.
7		To ensure the proper functioning of the device and in order to avoid risks of fire, use cables of suitable section in function of the currents involved and considering the cable length required for installation.
8		The device is battery operated, not normally provided by SMS . Be sure to use batteries appropriate to the device and to the charging current indicated to avoid the risk of explosion due to the release of hydrogen. Do not reverse the polarity of the batteries or short circuit. Consult the documentation provided by the battery manufacturer.

The examples and diagrams in this manual are included only for illustrative purposes. The contents of this manual are subject to change without notice. In no event will accept the liability for damages, indirect or consequential damages resulting from the use or application of the device.

1 – DESCRIPTION

The **PWB** inverter is used in rope lift systems to supply the main motor during the rescue operation.

Supplied by batteries of appropriate size, it provides the motor a 3-phase supply with adjustable voltage and frequency. It is available in 2 sizes:

Device	Product Code	Motor Power 380/415Vac (both VVVF and 1 or 2 speed)	Recommended Batteries
PWB 200	302.06.PWB1502	From 10 kW to 75 kW Nominal current from 20A to 150A (100 A for PMSM motors)	N.4 12V 18Ah (minimum)
PWB 300	302.06.PWB2002	From 10 kW to 100 kW Nominal current from 20A to 200A (133 A for PMSM motors)	N.4 12V 18Ah (minimum)

When the RUN input is activated, **PWB** drives the motor in both the run directions, testing the absorbed current. If in the second test the current is lower, the motor continues to move in that direction, otherwise it stops then moves in the first direction. If the current flows from the motor to the batteries (regenerated current), the run direction can be chosen even at the first trial.

If the overcurrent protection trips during the first test, **PWB** stops, reverses the run direction, then starts again its operation. If the overcurrent protection trips even in the second test, the protection trip is memorized and to reset it you must cut off the RUN input.

The overcurrent level adjustment is set during the device test in the factory, and it can't be modified.

To force the run in a definite direction, instead of choosing it depending on the lower current absorption, **PWB** must be supplied with 72V or 96V batteries, in order to allow the motor to have the nominal torque.

In this case it's necessary to activate also the UP or DOWN command, together with the RUN command.

The output short-circuit protection is ensured only if a 3-phase choke is connected between the inverter output and the motor.

PWB carries out the brake coil supply, through a rectifier and a control relay, as shown in the following diagram. The brake opening takes place only when a minimum motor current is detected, to be sure that a real connection between inverter and motor exists.

PWB can also inject DC current on the motor to obtain a precise stop at floor. When only RUN command is active, the activation of UP or DOWN input starts the DC current injection at the value set with 'X' trimmer. If UP or DOWN command is active from the start (as in a forced direction operation), the activation of the other direction starts the DC injection operation (i.e. if RUN is active with UP input, DOWN input activates DC).

2 – TECHNICAL CHARACTERISTICS

- Battery Voltage: 24-48-72-96 Vdc (Vb).
- 3-phase Output Voltage: 30% ÷ 60% of Vb , Vac
(Example : From 15 Vac to 30 Vac with Vb = 48Vdc)
- Output Frequency: 0.5 ÷ 5 Hz or 1 ÷ 10 Hz
- Maximum Output Current (Peak): 300A for **PWB** 200
370A for **PWB** 300

Hardware protections

- PTC, to protect against short-circuit the OUP and ODN outputs (run direction signals)

Software protections:

- Output current limit (peak): 300A (size 200) and 370A (size 300)
- Inverter overload control
- Check on Vb: Batteries run-down at -25% of Vb, over charged at +25% of Vb
- Check on motor minimum current
- Check on current regenerated towards batteries
- Check on the actual voltage in the brake circuit

3 – CONNECTIONS

PWB must be supplied with the necessary battery voltage at terminals PA – NA for the power section, and with 24Vdc (referred to NA) at the terminal 24VIN on the M1 terminal board, for the logic section.

The inverter is controlled through the commands available on terminal M1:

RUN	Run command
UP	Up direction command
DN	Down direction command
+CM	Command common
OUP	Up run direction signal command (24Vdc, 250mA, open collector)
ODN	Down run direction signal command (24Vdc, 250mA, open collector)
ORS	Extra, not currently used (24Vdc, 250mA, open collector)
+CM	Signal common

Brake control is available on terminal M2:

B~, B~	Brake input supply (Vac)
B+, B-	Brake output supply (Vdc)

Power section is available on the screw connections:

PA	Battery positive supply
NA	Battery negative supply
UA,VA,WA	Output for motor control

EXAMPLE OF DRAWING FOR RESCUE OPERATION WITH PWB INVERTER - 48V

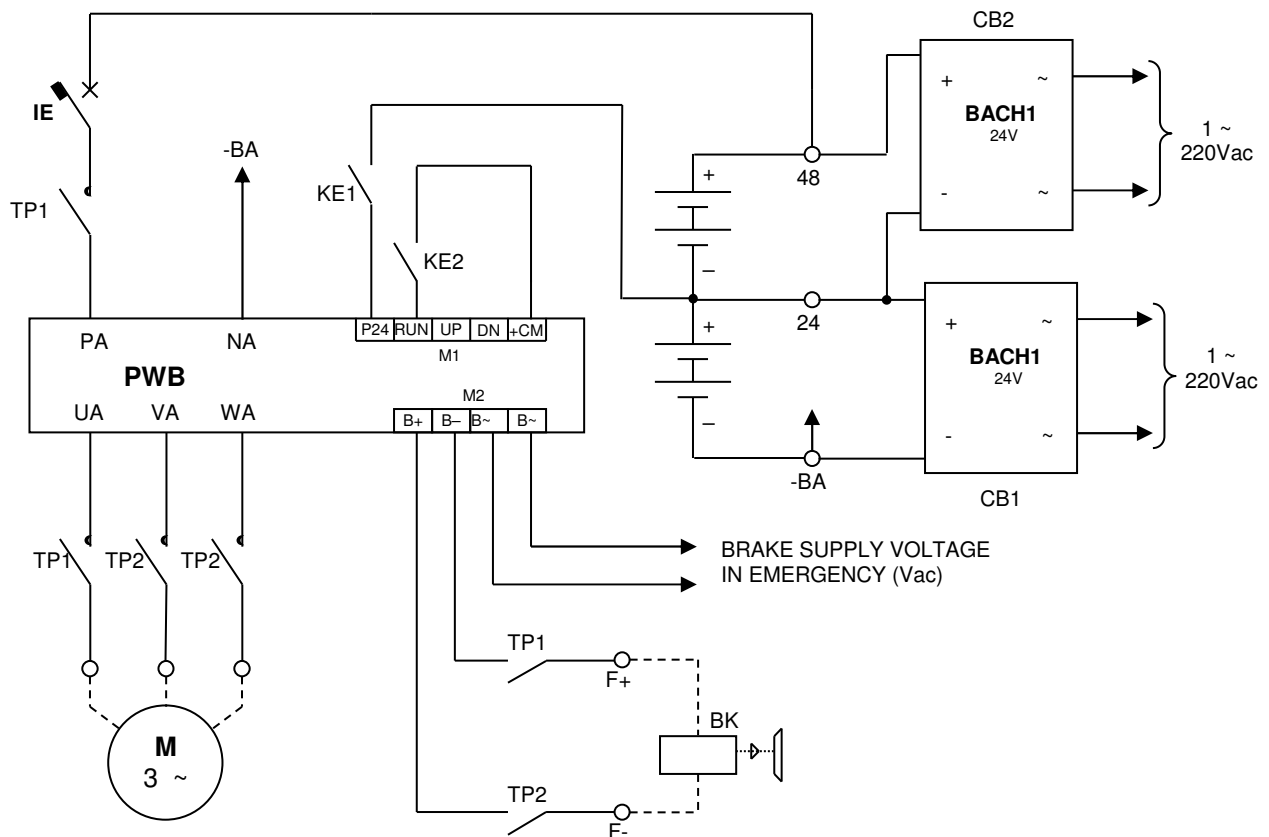

M	Motor	TP1,TP2	Motor contactors in rescue operation
BK	Brake	KE1	Rescue operation start command
CB1,CB2	Battery charger 24V	KE2	Inverter start command
IE	Main switch		(It must be activated at least 100msec after the TP1-TP2 activation and it must be cut off at least 100msec before the TP1-TP2 de-activation)

4 – ADJUSTMENTS AND SIGNALS

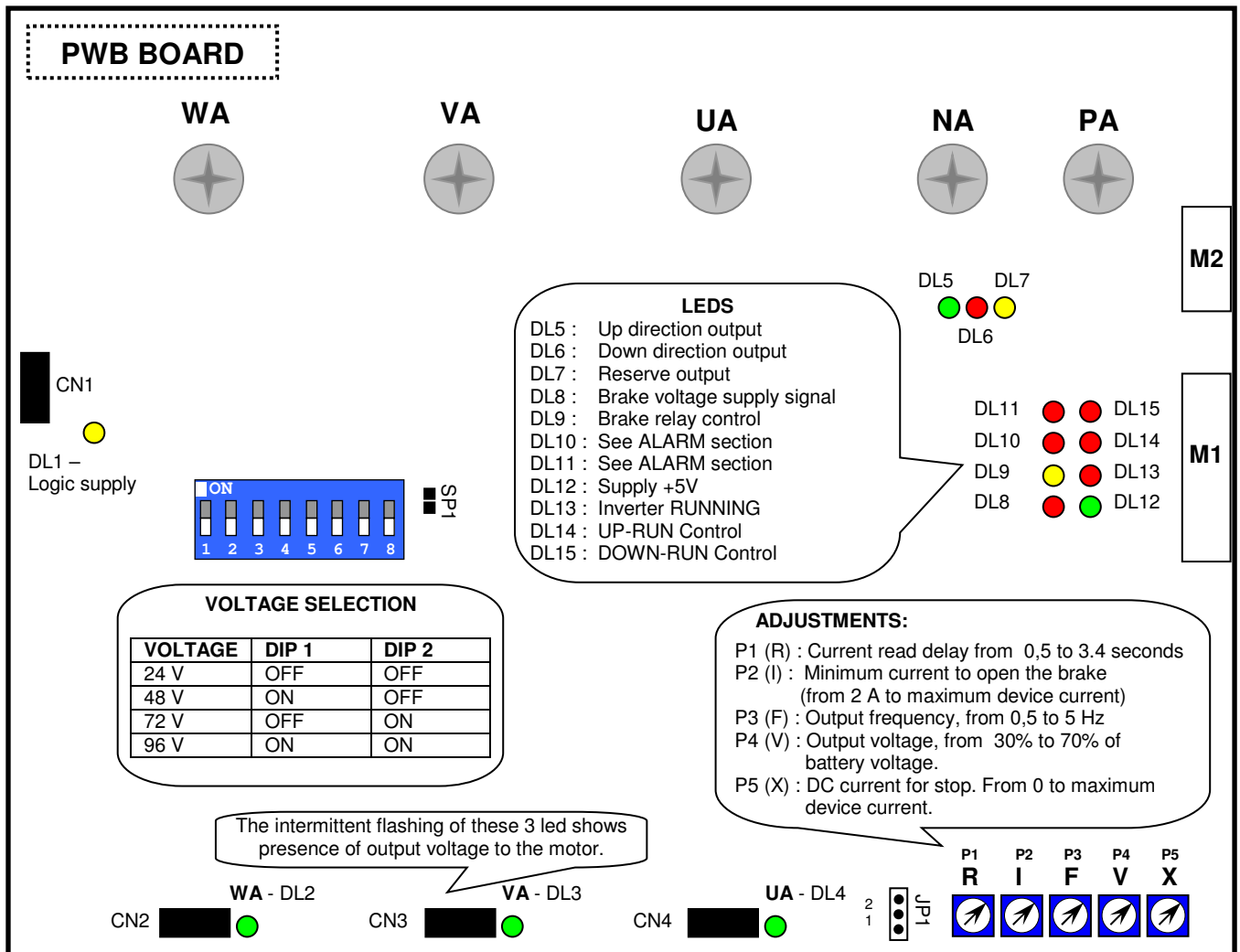

BOARD TERMINALS and SETTINGS	
UA,VA,WA : Motor Inverter Output	M1: P24 PWB logic part supply RUN 24V Input – Run control UP 24V Input – Forced UP-RUN DN 24V Input – Forced DOWN -RUN +CM PWB command common OUP Open Collector Output for up-run signal ODN Open Collector Output for down-run signal
PA,NA : Power Supply Input PA (+), NA (-)	
CN1 : Fan cooler supply	
CN2,CN3,CN4 : IGBT gate control	
M2 : Brake – Supply (B~, B-) and command (B+, B-)	
OTHER SETTINGS JP1 : DO NOT MODIFY. SP1 : DO NOT MODIFY. DIP1, DIP2 : VOLTAGE SELECTION DIP3 : ON=SVM MODULATION and FREQUENCY OUTPUT RANGE FROM 1 to 10Hz. OFF = PWM MODULATION and FREQUENCY OUTPUT RANGE FROM 0.5 to 5 Hz ⁽¹⁾ . DIP4 : BRAKE CONTROL VOLTAGE EXCLUDED. DIP5 : VOLTAGE CONTROL EXCLUDED. DIP6 : MOTOR COS FI CALCULATION EXCLUDED. DIP7 : NOT USED. DIP8 : NOT USED.	(¹) SVM modulation introduces a 3 rd harmonics on the output voltage, increasing its RMS value. It is normally used for asynchronous motors.

ALARMS		Description	Note:
Led DL10	Led DL11		
●	○	Battery voltage too low	Note: Callout : ○ = Led off ● = Led on * = Led flashing + = Led flashing slow
○	●	Battery voltage too high	
●	●	Brake voltage missing	
*	○	Output current too low	
○	*	Output peak current too high	
*	*	Output average current too high	
+	+	Overload	

5 – DIMENSIONS, WEIGHT AND MOUNTING HOLES

Width (mm)	Height (mm)	Depth (mm)	Weight (kg)
170	275	200	4.5
Mounting Holes : M5			

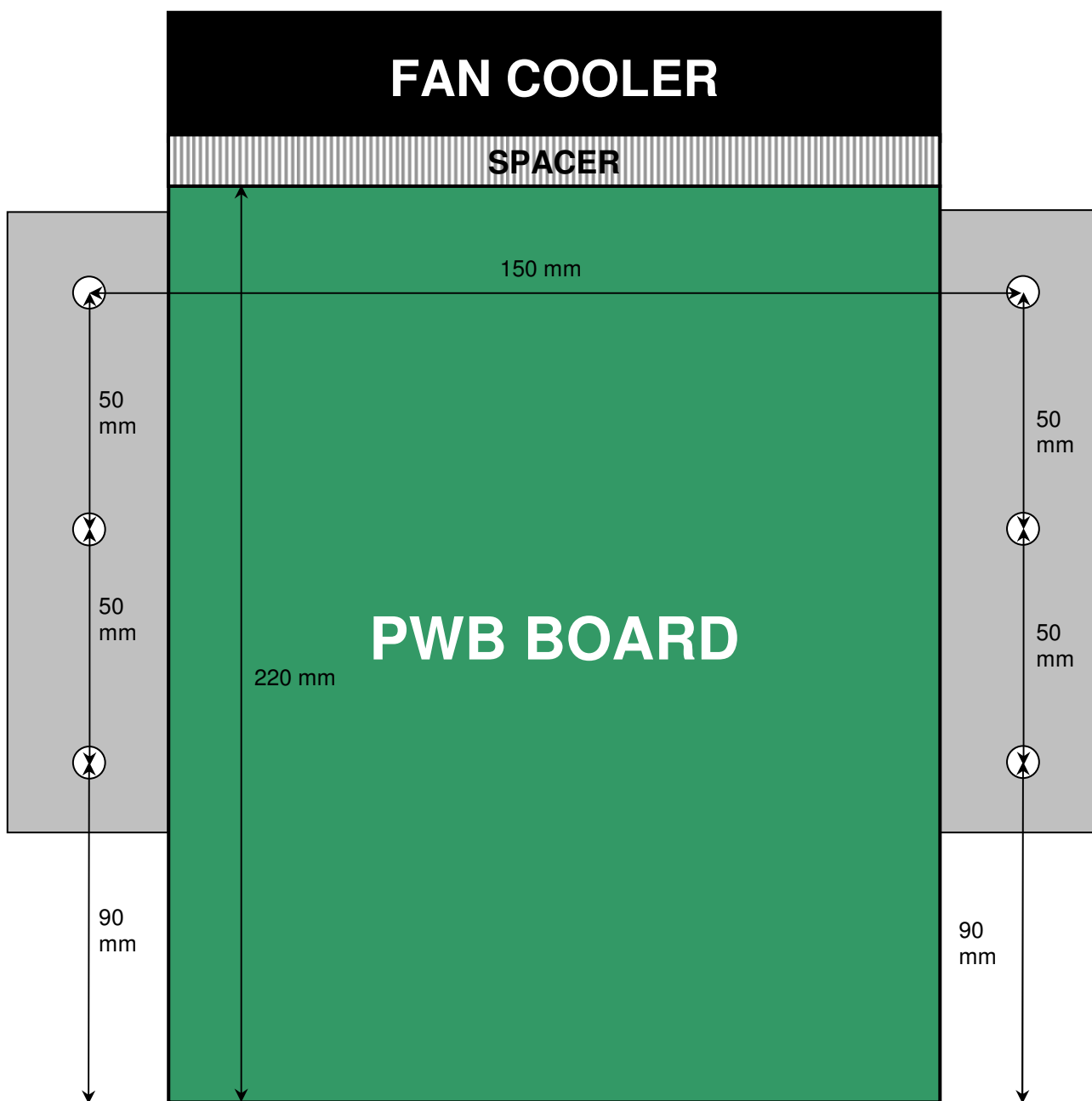

For further information please contact:

SMS S.R.L. (Gruppo SASSI HOLDING)

 **E-mail:** sms@sms.bo.it •
  **Website:** www.sms-lift.com •
  **Tel:** +39 051 969037 •
  **Address:** Via Guido Rossa 46-48-50 Loc. Crespellano 40053 Valsamoggia - Bologna - Italy

 **E-mail Technical Assistance:** assistentzatecnica@sms.bo.it •
  **Tel. Technical Assistance:** +39 051 6720710